

2E10-110-TX



1-Port EPo2 TX Adapter

AETEK EPo2(Ethernet & Power over 2 wires) kit allows you to connect PoE IP devices such as Intercom/Access Control/ Speaker/Touch Screen Station/VoIP/sensor/camera over in-wall 2 wires of doorbell wire, telephone line or 1-pair UTP/STP to Ethernet network. You don't have to configure anything, and you only need one AETEK EPo2 unit at each end of PoE IP device(PD) & Ethernet Switch port.

In addition to reuse 2-wire cable, AETEK EPo2 is designed to extend PoE range & data rates far beyond 100meters/100 Mbps limits even using 2-wire thinness 26AWG cable.

Features

- Uses telephone line, doorbell wire or 1-pair UTP/STP to connect PoE IP devices
- Eliminates extra intermediate PoE switch
- Plug-and-Play deployments
- Reuses in-wall 2 wires infrastructure
- Long reach PoE & high speed Ethernet rates up to 100Mbps
- Optional 19" 4-bay rack mount chassis(CH-100)

Applications

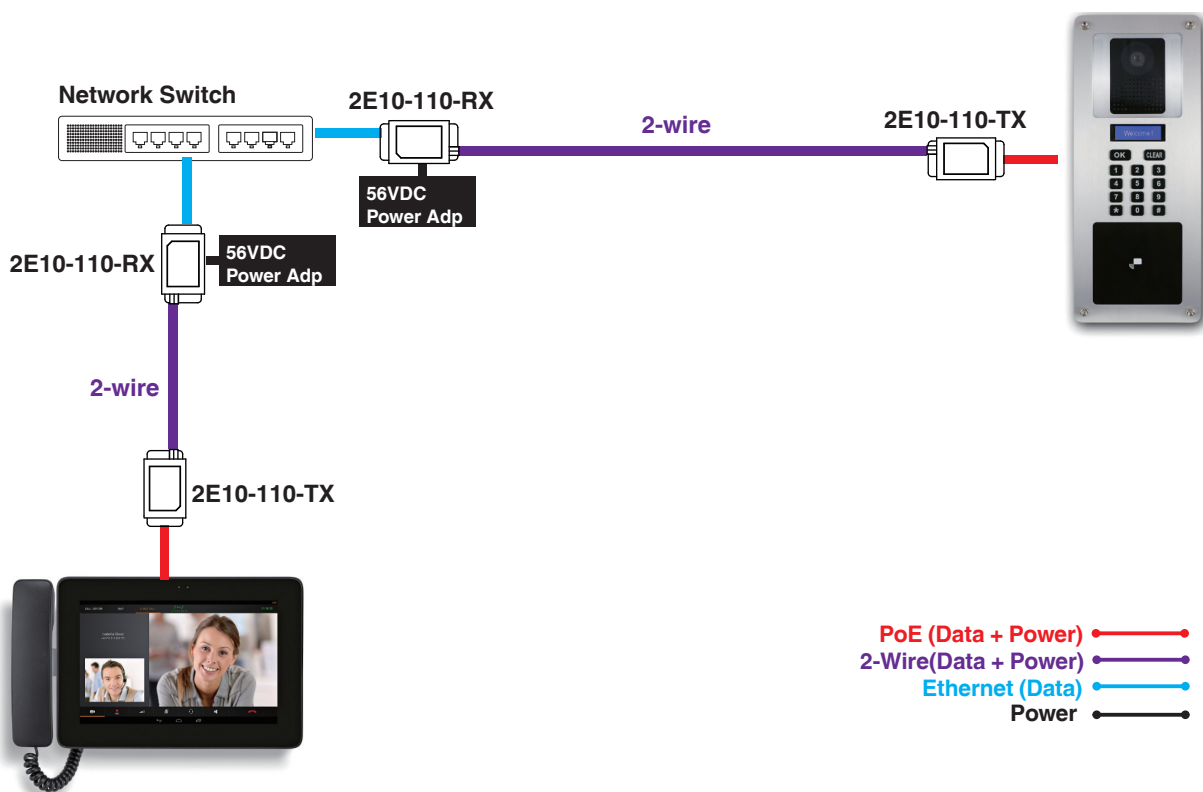

Applications

Inercom EPo2 Application

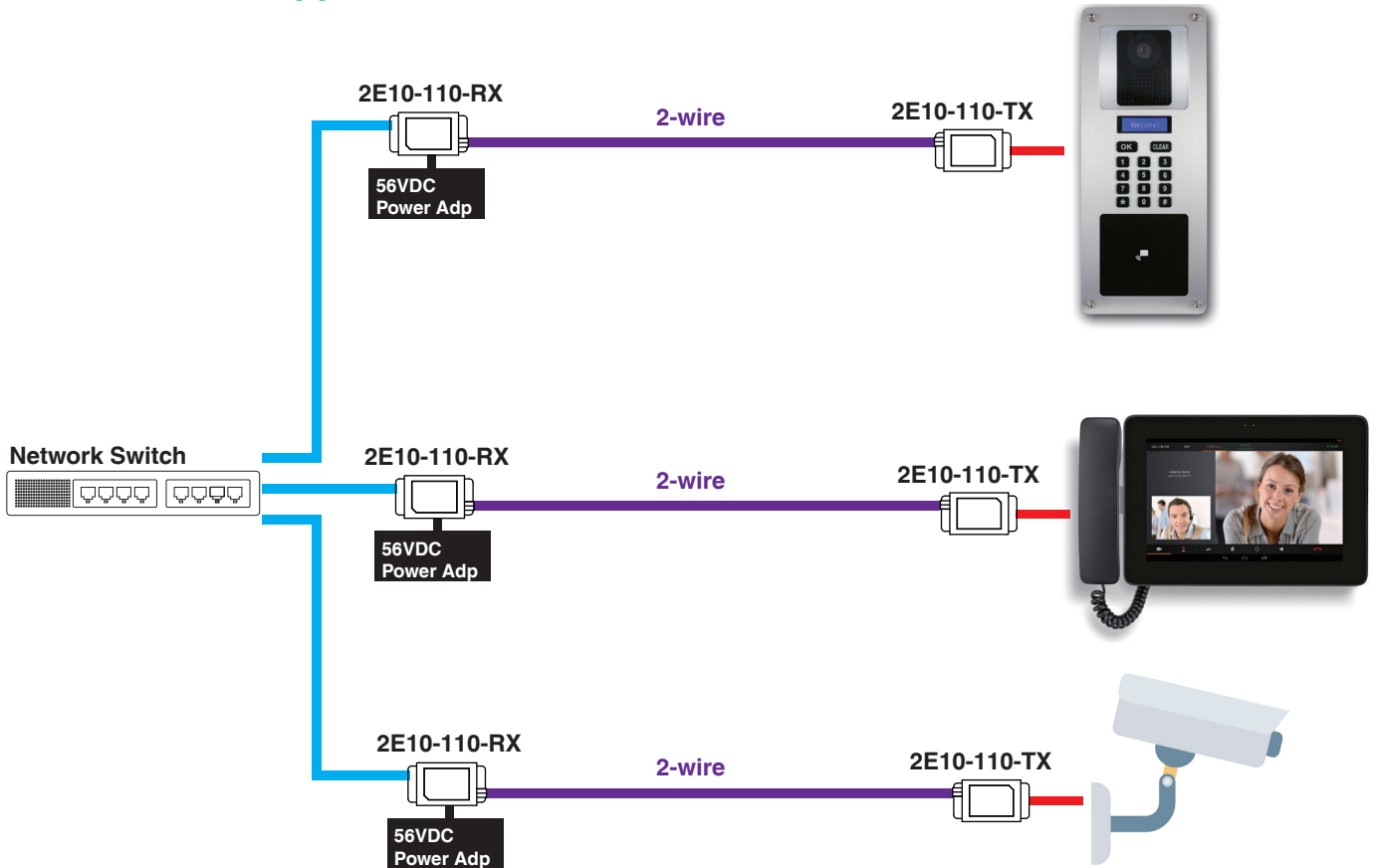

Elevator EPo2 Application

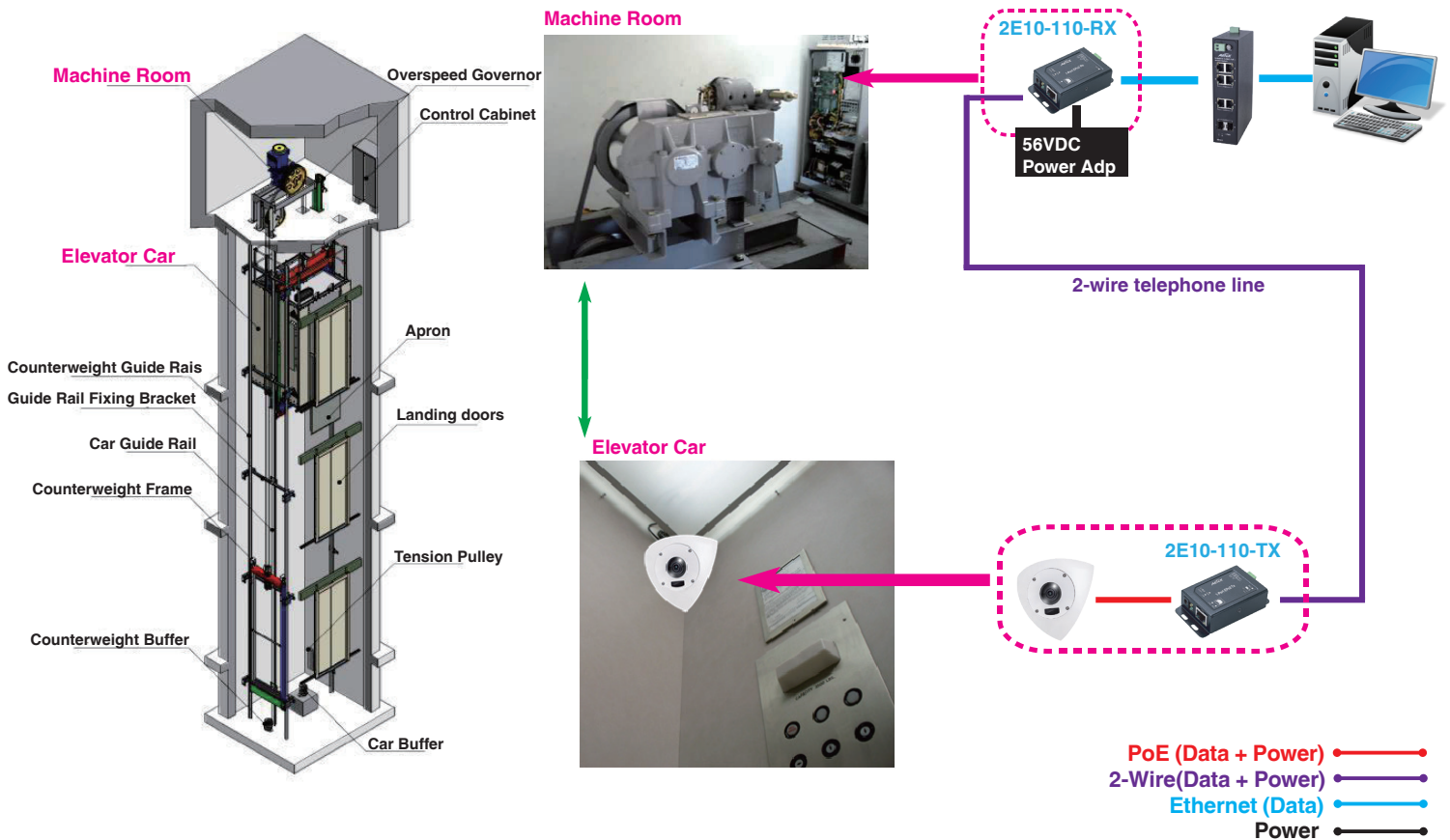

Specifications

Interface / Distance

2 Wire Link	2-Pin Terminal Block x1
10/100 Mbps Ethernet	PoE PSE RJ45 x1
Transmission mode	Transmitter TX mode
Cable Type	Doorbell wire 18/20/22 AWG, Telephone cable 24/26AWG UTP/STP cable: 23/24AWG
Bandwidth	100Mbps

Power Specifications

Power Input	EPo2@50~57VDC, 50~57 VDC power adapter
Power Output	Passive PoE (Compliant IEEE 802.3af PoE)
Unit Power Consumption	3 watts

Physical Specifications

Dimensions (LxWxH)	85.4 x 47.1 x 23 mm (3.36x1.85x0.91")
Weight	0.2 kg (0.44 lb)
Connectors	2P Terminal Blockx1, RJ45 x1, DC Jack x1, PoE On/Off Switch x1
Mounting Type	Wall mount

Environmental Specifications

Operating Temperature	-20°C ~ 60°C (-28°F ~ 140°F)
Storage Temperature	-20°C ~ 85°C (-28°F ~ 185°F)
Relative Humidity	5% ~ 95% non-condensing

Certifications

EMC	CE, FCC, VCCI, C-Tick
-----	-----------------------

LEDs

LAN	Ethernet status
PWR	Power status
LINK	EPo2 RX device connect status
POE	PoE status

Power / Distance Chart

	100m	200m	400m
0.4mm Cable 26AWG	Watt : 18W	Watt : 8.06W	X
0.5mm Cable 24AWG	Watt : 23.8W	Watt : 12.1W	X
0.6mm Cable 22AWG	Watt : 32.3W	Watt : 17.2W	Watt : 8.4W
Data Rate	100Mbps	100Mbps	100Mbps

Related Products

EPo2 (RX)



2E10-110-RX
• 2E10-110 EPo2 adapter(RX)
• 65W@56VDC power adapter



2E11-110-RX
• 2E11-110 PoE EPo2 adapter(RX)
• Supports 30W/60W/95W PoE Input